

Ethicon Product Overview & Materials Design Considerations



Ryan Laurent – R&D Manager, Lifecycle Engineering

Aug 23, 2023

Topics

- ✓ Surgical Approach
- ✓ Surgical Specialties
- ✓ Ethicon Product Categories
- ✓ Ethicon Product Development Process
- ✓ Medical Device Material Considerations
- ✓ Materials Selection Case Study



Surgical Approach Common for Ethicon Products



Robotic Surgery
~20 Years



Laparoscopic Surgery
~40 Years



Open Surgery
~100 Years

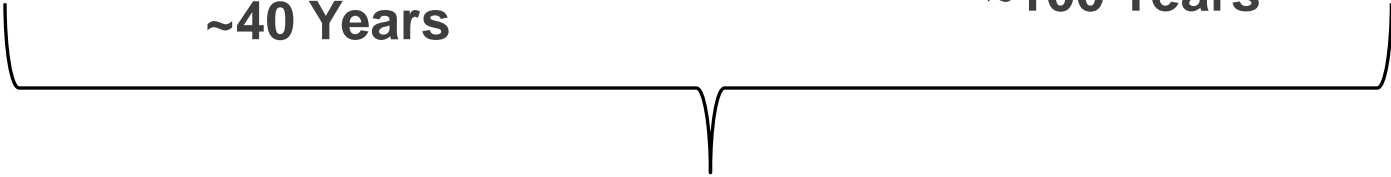

Handheld Devices

Ethicon Products Surgical Specialties



General Surgery



Thoracic Surgery

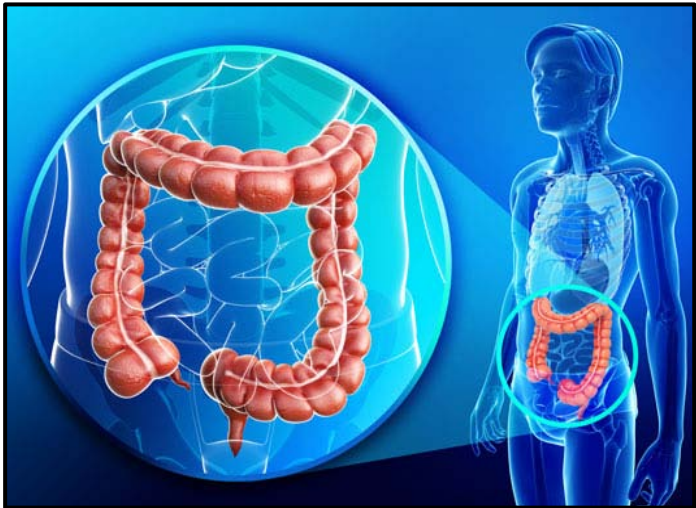

Colorectal Surgery



Bariatric Surgery

Ethicon Surgical Device Product Categories

Access



Energy



Surgical Stapling

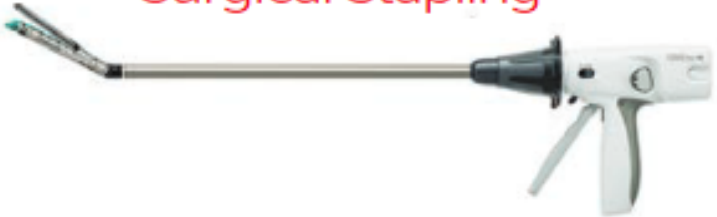

Wound Closure



Ligation



Magnetic Sphincter Augmentation



Hernia Repair & Fixation



Medical Device Material Considerations

Single Patient Use Devices

- Mechanical Properties
- Manufacturing Properties
- Dimensional Accuracy
- Biocompatibility
- Sterilization (Gamma / EO)
- Material Stability (5 Year Shelf Life)
- Material Cost
- Supply Chain Stability & Continuity
- Environmental / Disposal Considerations

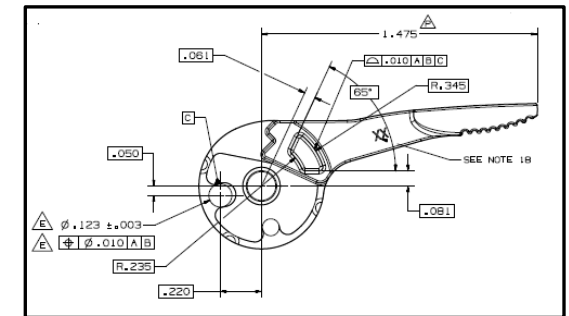
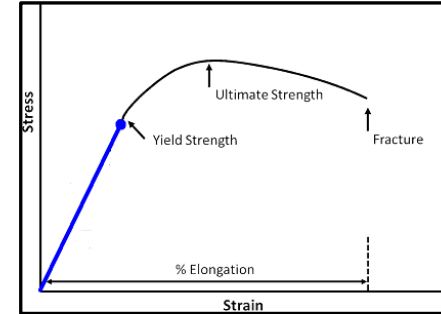

A Very Demanding List of Material Requirements!!!

Medical Device Material Considerations

Multi-Patient Use Devices

- Similar material requirements as Single Patient Use.....
- Can absorb slightly higher material costs (*amortize COGS over multiple procedures*)
- Reusable devices generally contain more metallic components
- Often leverage Autoclave Sterilization within the hospital



Hand Piece
Single Patient Use



Transducer
Multi-Patient Use



Multi-Patient Use
Forceps



Multi-Patient Use
Clip Applier

Ethicon Product Development Process

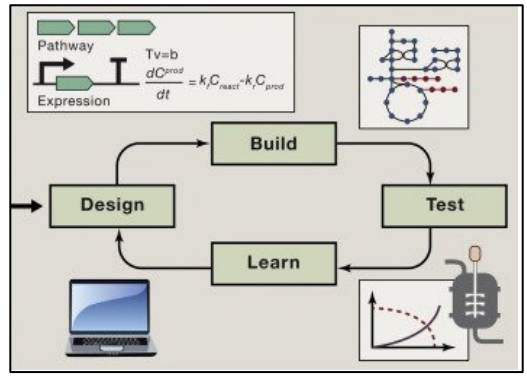
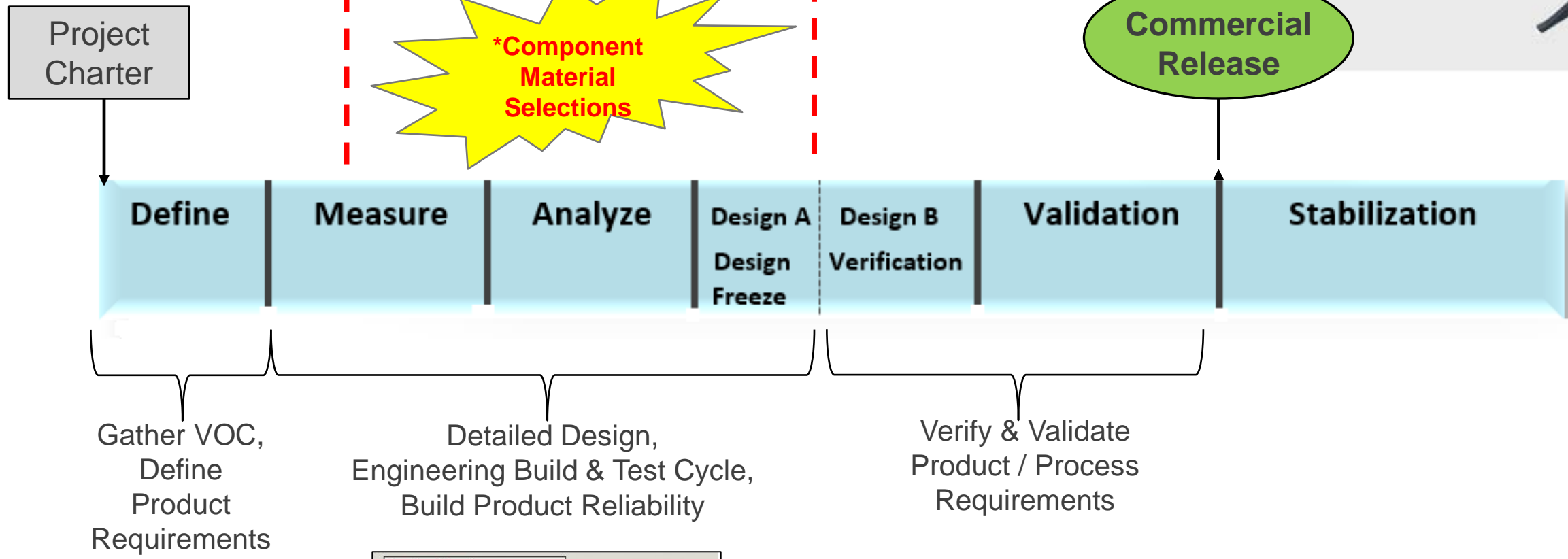

*Material selections

Ethicon Product Change Process

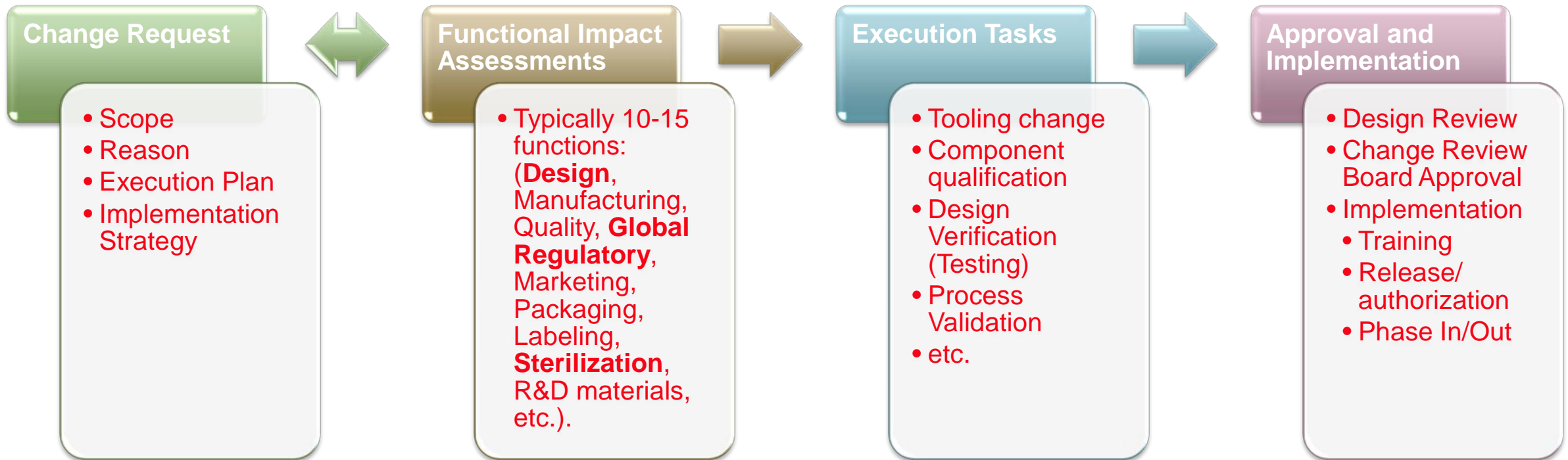
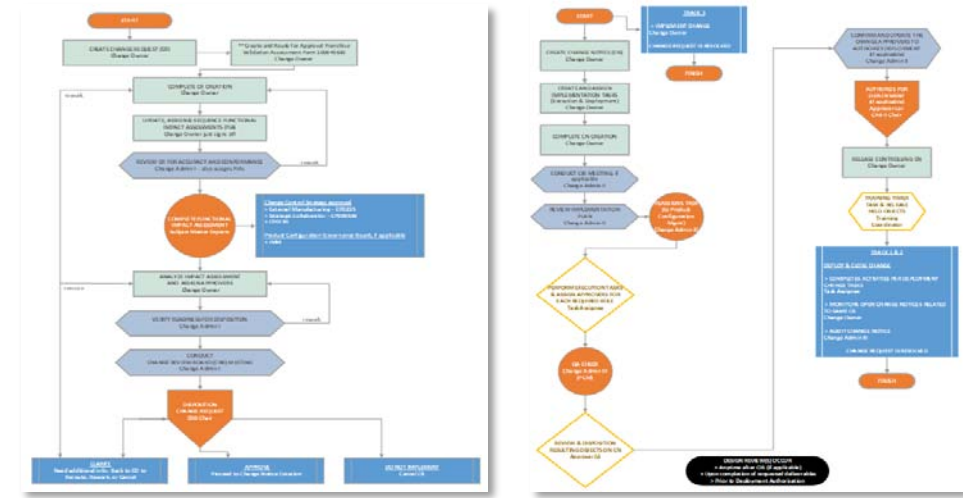

Case Study – Plastic Endocutter PCR

Project Goal: Create lower cost plastic Prox Channel Retainer *to replace 7075-T6 design*

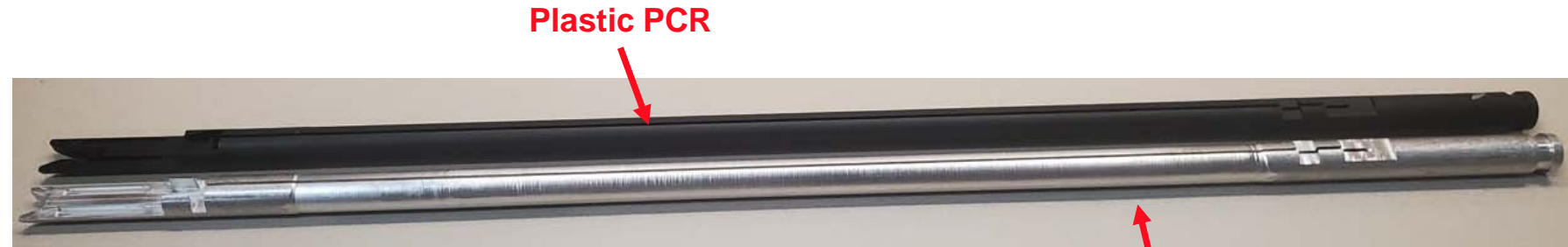

Plastic PCR

Predicate Aluminium PCR

Material Considerations

- Device Performance & Reliability must be maintained!!!
- Withstand over 200lbs of tensile force
- Elastic Modulus & Yield Strength similar to Aluminum
- Injection Moldability & Dimensional Accuracy

Results

- Change was transparent to the Surgeon customer
- Material Selected: 40% Carbon Filled Nylon
- ~\$10/device COGS reductions

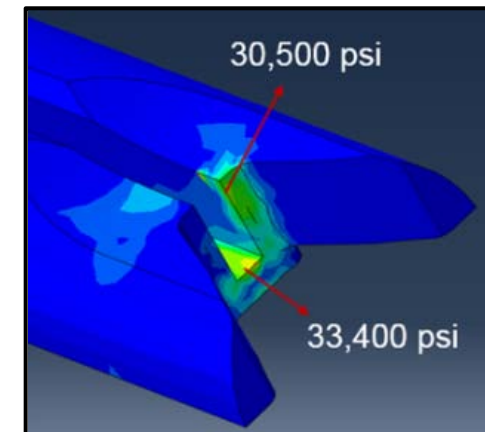
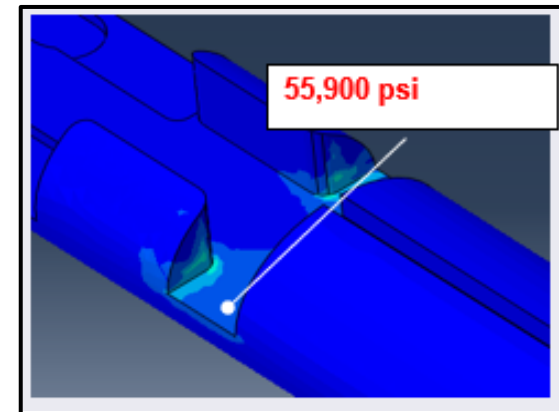

THANK YOU!!



ETHICON

Shaping the future of surgery